

CAMPANAS
OMT
Especificaciones:

MODELO	MOTOR (KW)	MOTOR (HP)
TH20A	0.55 - 1.5	0.75 - 2
THB20		
TH1		
THB-25	2.2 - 4	3 - 5.5
TH2		
THB-30	5.5 - 9	7.5 - 12.5
TH3		
L35C	11 - 22	15 - 30
TH4		
TH15	30	40
TH18	37 - 45	50 - 60
TH19	55 - 90	75 - 125
TH20	110	150

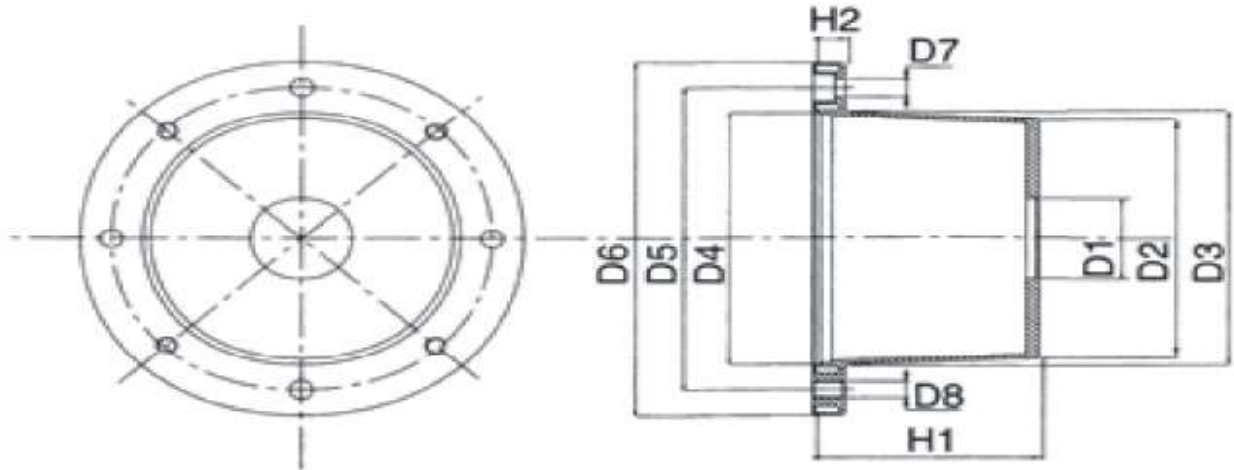

MODELO	D1	D2	D3	D4	D5	D6	D7	N° AGUJEROS	D8	H1	H2
TH20A	45	130	135	130	165	200	12	4	M10	95	16
THB20	50	130	135	130	165	200	12	4	M10	113	16
TH1	63	130	135	130	165	200	12	4	M10	126	16
THB-25	50	176	183	180	215	250	14	4	M12	112	21
TH2	63	176	183	180	215	250	14	4	M12	136	21
THB-30	80	230	235	230	265	300	14	4	M12	130	21
TH3	80	230	235	230	265	300	14	4	M12	170	21
L35C	80	240	253	250	300	350	18	4	M16	178	25
TH4	80	240	253	250	300	350	18	4	M16	195	25
TH15	100	235	295	300	350	400	18	4	M16	206	25
TH18	100	260	350	350	400	450	18	8	M16	280	25
TH19	100	300	450	450	500	550	18	8	M16	290	30
TH20	100	300	550	550	600	660	22	8	M20	295	35

Para mayor informacion consultar a nuestro departamento técnico.